

Industrial Hydraulics | Mobile Hydraulics | Hydraulic Power Packs | Hydraulic Cylinders | Services

## A2FO

Fixed Displacement Bent Axis piston pump  
Series 61  
Size 10 to 180 cc  
Nominal pressure: 400 bar  
Maximum pressure: 450 bar



## Index

## Page No

• Features	02
• Specifications	02
• Ordering code	03
• Technical data	04
• Unit Dimensions Size 10, 12, 16	05
• Unit Dimensions Size 23, 28, 32	06
• Unit Dimensions Size 45	07
• Unit Dimensions Size 56, 63	08
• Unit Dimensions Size 80, 90	09
• Unit Dimensions Size 107, 125	10
• Unit Dimensions Size 160, 180	11
• Installation Notes for A2FO Axial piston units	12
• General Instructions	15

## Features

- Fixed displacement pump A2FO of axial piston, bent axis design is made suitable for hydrostatic drives in open circuits.
- Suitable for use in mobile or industrial applications.
- Output flow is proportional to drive speed and displacement.
- The drive shaft bearings are designed to give the service life expected in these areas of operation.
- Careful selection of the displacements offered, permit sizes to be matched to practically every application.
- Favorable power/Weight ratio.
- Compact and economical design
- Optimum efficiency
- One piece pistons with piston rings

## Specifications

Size			10	12	16	23	28	32	45	56	
Displacement	$V_g$	cm <sup>3</sup>	10.3	12.0	16.0	22.9	28.1	32	45.6	56.1	
Max. speed	$n_{max}$ 1)	rpm	3150	3150	3150	2500	2500	2500	2240	2000	
Max. perm. speed with increased input pressure $P_{abs}$	$n_{max,perm.}$ 2)	rpm	6000	6000	6000	4750	4750	4750	4250	3750	
Max. perm. output flow at $n_{max}$	$q_{vmax}$	l/min	32.4	37.8	50	57	70	80	102	112	
Max. power at $q_{vmax}$	$\Delta p=350$ bar	$P_{max}$	kW	18.9	22	29.2	33	41	47	59.5	65
	$\Delta p=400$ bar	$P_{max}$	KW	21.6	25	34	38	47	53	68	75
Perm. torque	$\Delta p=350$ bar	T	Nm	57	67	88	126	156	178	254	312
	$\Delta p=400$ bar	T	Nm	65	76	101	145	178	203	290	356
Case volume		L	0.17	0.17	0.17	0.20	0.20	0.20	0.33	0.45	
Weight (approx.)	m	kg	6	6	6	9.5	9.5	9.5	13.5	18	

Size			63	80	90	107	125	160	180	
Displacement	$V_g$	cm <sup>3</sup>	63	80.4	90	106.7	125	160.4	180	
Max. speed	$n_{max}$ 1)	rpm	2000	1800	1800	1600	1600	1450	1450	
Max. perm. speed with increased input pressure $P_{abs}$	$n_{max,perm.}$ 2)	rpm	3750	3350	3350	3000	3000	2650	2650	
Max. perm. output flow at $n_{max}$	$q_{vmax}$	l/min	126	144	162	170	200	232	261	
Max. power at $q_{vmax}$	$\Delta p=350$ bar	$P_{max}$	kW	73.5	84	95	100	117	135	152
	$\Delta p=400$ bar	$P_{max}$	KW	84	96	108	114	133	155	174
Perm. torque	$\Delta p=350$ bar	T	Nm	350	445	501	594	696	893	1003
	$\Delta p=400$ bar	T	Nm	400	511	572	678	795	1020	1145
Case volume		L	0.45	0.55	0.55	0.8	0.8	1.1	1.1	
Weight (approx.)	m	kg	18	23	23	32	32	45	45	

1) the values shown are valid for an absolute pressure ( $P_{abs}$ ) of 1 bar at the suction inlet S and when operated on mineral oil (with a specific mass of 0.88kg/L).

2) by increase of the input pressure ( $P_{abs} > 1$  bar) the rotational speeds can be increased to the max. admissible speeds  $n_{max}$  limit (speed limits)

### Determining the size:

$$\text{Flow} \quad q_v = \frac{V_g \times n \times n_v}{1000} \quad [ \text{L/min} ]$$

$$\text{Torque} \quad T = \frac{V_g \times \Delta P}{20\pi \times n_{mh}} \quad [ \text{Nm} ]$$

$$\text{Power} \quad P = \frac{2\pi \times T \times n}{60000} = \frac{q_v \times \Delta P}{600 \times n_t} \quad [ \text{kW} ]$$

$V_g$  = Displacement per revolution in mL/r

$\Delta P$  = Differential pressure in bar

$n$  = Speed in rpm

$n_v$  = Volumetric efficiency

$n_{mh}$  = Mechanical-hydraulic efficiency

$n_t$  = Overall efficiency

## Ordering code

<p><b>Axial piston unit</b> Bent axis design, fixed displacement for use with mineral oil = A2F</p>																																																																																					
<p><b>Mode of operations</b> Pump, Open circuit = O</p>																																																																																					
<p><b>Size (Displacement V mL/rg<sup>3</sup>)</b> 10, 12, 16, 23, 28, 32, 45, 56, 63, 80, 90, 107, 125, 160, 180</p>																																																																																					
<p><b>Series</b> = 6</p>																																																																																					
<p><b>Index</b> = 1</p>																																																																																					
<p><b>Direction of rotation(View on shaft end)</b> Clockwise = R Anti-Clockwise = L</p>																																																																																					
<p><b>Seals</b> NBR (nitril- caoutchouc) = P FKM (fluor- caoutchouc) = V</p>																																																																																					
<p><b>Shaft end</b></p> <table border="1" style="width: 100%; border-collapse: collapse; text-align: center;"> <thead> <tr> <th></th> <th>10</th> <th>12</th> <th>16</th> <th>23</th> <th>28</th> <th>32</th> <th>45</th> <th>56</th> <th>63</th> <th>80</th> <th>90</th> <th>107</th> <th>125</th> <th>160</th> <th>180</th> <th></th> </tr> </thead> <tbody> <tr> <td>Splined shaft DIN 5480</td> <td>●</td><td>●</td><td>●</td><td>●</td><td>●</td><td>●</td><td>-</td><td>●</td><td>●</td><td>●</td><td>●</td><td>●</td><td>●</td><td>●</td><td>●</td><td>A</td> </tr> <tr> <td></td> <td>●</td><td>●</td><td>-</td><td>●</td><td>●</td><td>-</td><td>●</td><td>●</td><td>-</td><td>●</td><td>-</td><td>●</td><td>-</td><td>●</td><td>-</td><td>Z</td> </tr> <tr> <td rowspan="2">Parallel shaft with key, DIN 6885</td> <td>●</td><td>●</td><td>●</td><td>●</td><td>●</td><td>●</td><td>-</td><td>●</td><td>●</td><td>●</td><td>●</td><td>●</td><td>●</td><td>●</td><td>●</td><td>B</td> </tr> <tr> <td>●</td><td>●</td><td>-</td><td>●</td><td>●</td><td>-</td><td>●</td><td>●</td><td>-</td><td>●</td><td>-</td><td>●</td><td>-</td><td>●</td><td>-</td><td>P</td> </tr> </tbody> </table>		10	12	16	23	28	32	45	56	63	80	90	107	125	160	180		Splined shaft DIN 5480	●	●	●	●	●	●	-	●	●	●	●	●	●	●	●	A		●	●	-	●	●	-	●	●	-	●	-	●	-	●	-	Z	Parallel shaft with key, DIN 6885	●	●	●	●	●	●	-	●	●	●	●	●	●	●	●	B	●	●	-	●	●	-	●	●	-	●	-	●	-	●	-	P	
	10	12	16	23	28	32	45	56	63	80	90	107	125	160	180																																																																						
Splined shaft DIN 5480	●	●	●	●	●	●	-	●	●	●	●	●	●	●	●	A																																																																					
	●	●	-	●	●	-	●	●	-	●	-	●	-	●	-	Z																																																																					
Parallel shaft with key, DIN 6885	●	●	●	●	●	●	-	●	●	●	●	●	●	●	●	B																																																																					
	●	●	-	●	●	-	●	●	-	●	-	●	-	●	-	P																																																																					
<p><b>Flange mounting</b></p> <table border="1" style="width: 100%; border-collapse: collapse; text-align: center;"> <thead> <tr> <th></th> <th>10</th> <th>12</th> <th>16</th> <th>23</th> <th>28</th> <th>32</th> <th>45</th> <th>56</th> <th>63</th> <th>80</th> <th>90</th> <th>107</th> <th>125</th> <th>160</th> <th>180</th> <th></th> </tr> </thead> <tbody> <tr> <td>ISO 4-hole</td> <td>●</td><td>●</td><td>●</td><td>●</td><td>●</td><td>●</td><td>●</td><td>●</td><td>●</td><td>●</td><td>●</td><td>●</td><td>●</td><td>●</td><td>●</td><td>B</td> </tr> </tbody> </table>		10	12	16	23	28	32	45	56	63	80	90	107	125	160	180		ISO 4-hole	●	●	●	●	●	●	●	●	●	●	●	●	●	●	●	B																																																			
	10	12	16	23	28	32	45	56	63	80	90	107	125	160	180																																																																						
ISO 4-hole	●	●	●	●	●	●	●	●	●	●	●	●	●	●	●	B																																																																					
<p><b>Service line connections 1)</b></p> <table border="1" style="width: 100%; border-collapse: collapse; text-align: center;"> <thead> <tr> <th></th> <th>10</th> <th>12</th> <th>16</th> <th>23</th> <th>28</th> <th>32</th> <th>45</th> <th>56</th> <th>63</th> <th>80</th> <th>90</th> <th>107</th> <th>125</th> <th>160</th> <th>180</th> <th></th> </tr> </thead> <tbody> <tr> <td>A(B) SAE, at side S SAE, at rear</td> <td>-</td><td>-</td><td>-</td><td>●</td><td>●</td><td>●</td><td>●</td><td>●</td><td>●</td><td>●</td><td>●</td><td>●</td><td>●</td><td>●</td><td>●</td><td>05</td> </tr> <tr> <td>A (B) threads at side S threads, at rear</td> <td>●</td><td>●</td><td>●</td><td>-</td><td>-</td><td>-</td><td>-</td><td>-</td><td>-</td><td>-</td><td>-</td><td>-</td><td>-</td><td>-</td><td>-</td><td>06</td> </tr> </tbody> </table>		10	12	16	23	28	32	45	56	63	80	90	107	125	160	180		A(B) SAE, at side S SAE, at rear	-	-	-	●	●	●	●	●	●	●	●	●	●	●	●	05	A (B) threads at side S threads, at rear	●	●	●	-	-	-	-	-	-	-	-	-	-	-	-	06																																		
	10	12	16	23	28	32	45	56	63	80	90	107	125	160	180																																																																						
A(B) SAE, at side S SAE, at rear	-	-	-	●	●	●	●	●	●	●	●	●	●	●	●	05																																																																					
A (B) threads at side S threads, at rear	●	●	●	-	-	-	-	-	-	-	-	-	-	-	-	06																																																																					

= preferred type  
 ● = available  
 - = not available

1) fastening threads resp.threaded ports are metric

## Technical data

### Hydraulic fluid

The A2FO fixed displacement pump is suitable for use with mineral oil.

### Viscosity range

We recommend that a viscosity (at operating temperature) for optimum efficiency and service life purposes of

$$V_{opt} = \text{optimum viscosity } 16 \dots 36 \text{ mm}^2/\text{s}$$

Be chosen, taken the tank temperature (open circuit) into account.

### Limits of viscosity range

The following values apply in extreme cases:

$$V_{min} = 5 \text{ mm}^2/\text{s}$$

short term ( $t < 3 \text{ min}$ ) at max. permitted temperature

$$t_{max} = 115^\circ\text{C}$$

$$2 V_{max} = 1600 \text{ mm}^2/\text{s}$$

short term ( $t < 3 \text{ min}$ ) with cold start ( $P < 30 \text{ bar}$ ,

$$n \leq 1000 \text{ rpm } t_{min} = -40^\circ\text{C}$$

Note that the maximum hydraulic fluid temperature must not be exceeded locally either (e.g. bearing area). The temperature in the bearing area is depending on pressure and speed up to 12 K higher than the average case drain temperature.

### Selection diagram

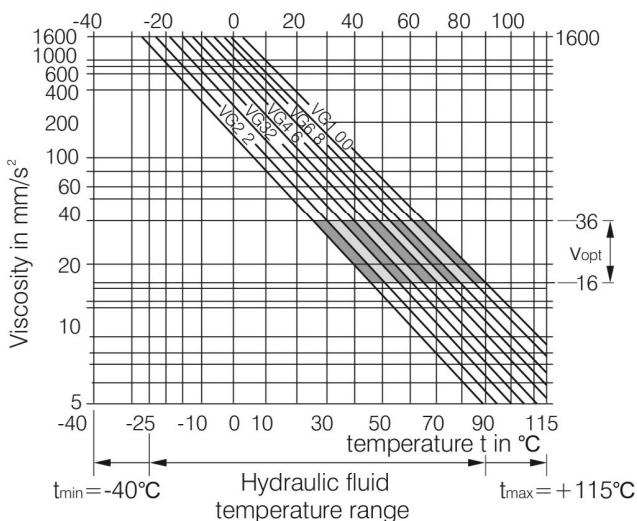

### Details regarding the choice of hydraulic fluid

The correct selection of hydraulic fluid requires knowledge of the operating temperature in relation to the ambient temperature, in an open circuit the tank temperature.

The hydraulic fluid should be selected so that within the operating temperature range, the operating viscosity lies within the optimum range ( $V_{opt}$ ) (see shaded section of the selection diagram). We recommend that the highest possible viscosity range should be chosen in each case.

Example: At an ambient temperature of  $X^\circ\text{C}$  an operating temperature of  $60^\circ\text{C}$  is set in the circuit. In the optimum operating viscosity range ( $V_{opt}$ ; shaded area) this corresponds to the viscosity classes VG 46 or VG 68; to be selected: VG 68.

Please note: The leakage fluid temperature, which is affected by pressure and rotational speed, is always higher than the tank temperature. At no point in the system may the temperature be higher than  $115^\circ\text{C}$ .

### Filteration

The finer the filtration, the cleaner the fluid and the longer the service life of the axial piston unit.

To ensure proper function of the axial piston unit, the hydraulic fluid must have a cleanliness level of at least 20/18/15 according to ISO 4406.

At very high hydraulic fluid temperatures ( $90^\circ\text{C}$  to max.  $115^\circ\text{C}$ ), a cleanliness level of at least 19/17/14 according to ISO 4406 is required.

### Operational pressure range

#### Inlet

Pressure at port S

The minimum inlet pressure depends on speed. The following limits must not be exceeded.

$$P_{abs \text{ min}} \text{ ----- } 0.8 \text{ bar}$$

$$P_{abs \text{ max}} \text{ ----- } 30 \text{ bar}$$

#### Minimum inlet pressure at suction port S with increased speed

In order to avoid damage of the pump a minimum inlet pressure at the suction port must be assured. The minimum inlet pressure is related to the rotational speed of the fixed pump.

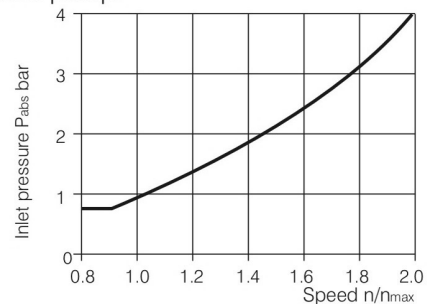

Note: max. permissible speed  $n_{max \text{ perm.}}$  (speed limit)  
min. permissible inlet pressure at port S  
admissible values for the drive shaft seal

### Outlet

Maximum pressure on port A or B (pressure data according to DIN 24312)

	Shaft end A, Z	Shaft end B, P
Nominal pressure $P_N$	400bar	350bar
Peak pressure $P_{max}$	450bar	400bar

### Direction of flow

Direction of rotation, viewed on shaft end	clockwise	counter-clockwise
S to B		S to A

### Symbol

Connections	
A, B	Service line port
S	Suction port
$T_1, T_2$	Drain ports

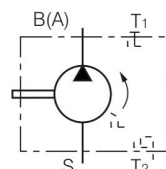

**Unit Dimension Size 10, 12, 16**

**(Dimension in mm)**

illustration: cw direction of rotation (on version "ccw direction of rotation" the port plate is rotated through 180°)

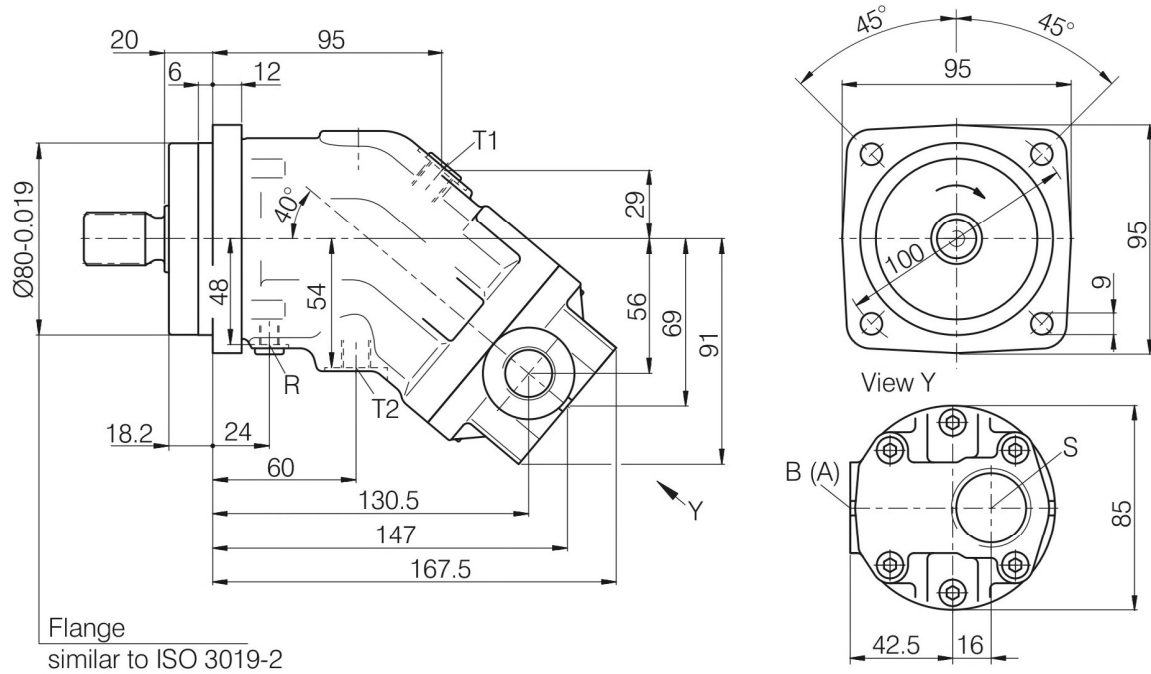

Flange  
similar to ISO 3019-2

**Shaft ends**

Sizes 10, 12, 16

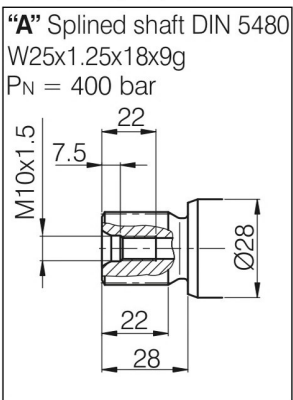

Sizes 10, 12,

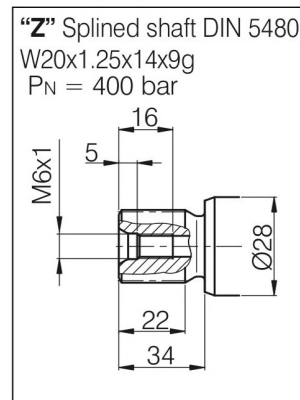

Sizes 10, 12, 16

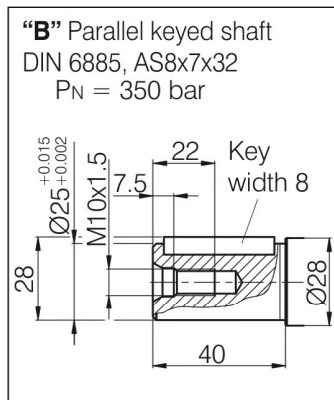

Sizes 10, 12,

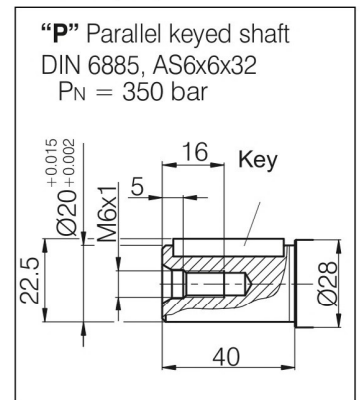

**Port details**

Designation	Port for	Standard	Maximum pressure (bar)
B/A	Service line, fastening thread B/A	M22x1.5; 14 deep	400
S	Suction line, fastening thread	M33x2; 18 deep	30
T1	Case drain line	M12x1.5; 12 deep	3
T2	Case drain line	M12x1.5; 12 deep	3
R	Air bleed	M8x1; 8 deep	3

**Unit Dimension Size 23, 28, 32**

**(Dimension in mm)**

Port plate 05-SAE flange port A/B at side and SAE flange port S at rear

illustration: cw direction of rotation (on version "ccw direction of rotation" the port plate is rotated through 180°)

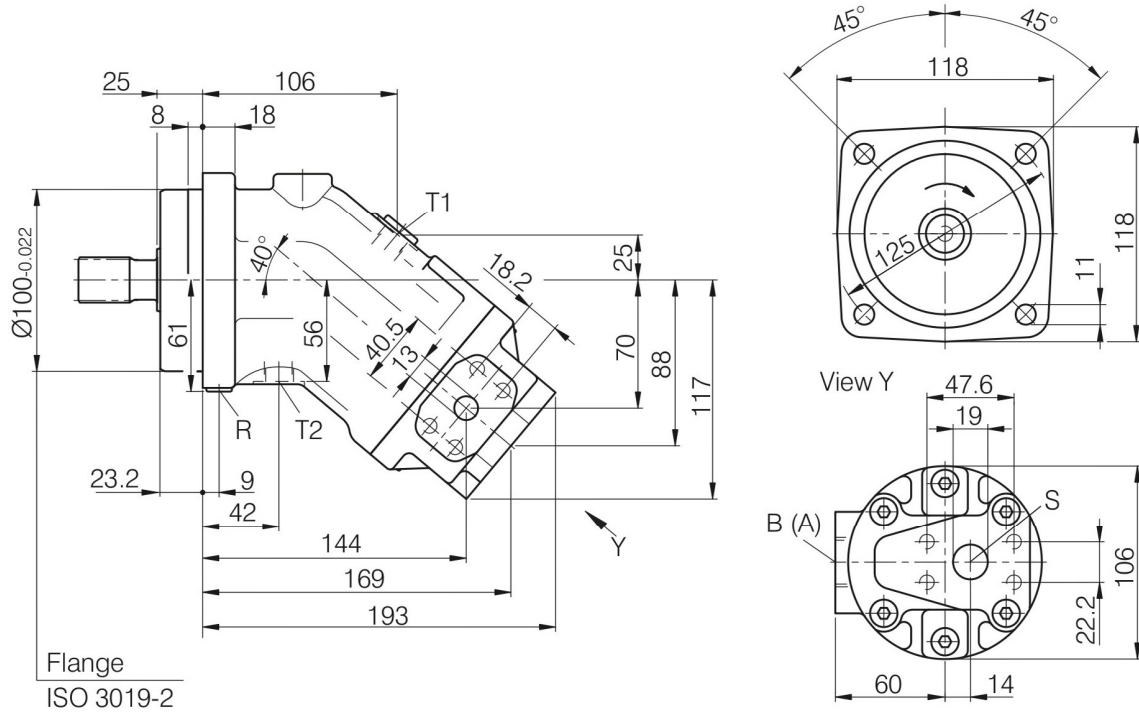

**Drive shaft**

Sizes 23, 28, 32

**"A"** Splined shaft DIN 5480  
W30x2x14x9g

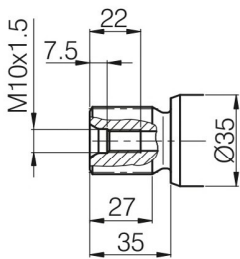

Sizes 23, 28

**"Z"** Splined shaft DIN 5480  
W25x1.25x18x9g

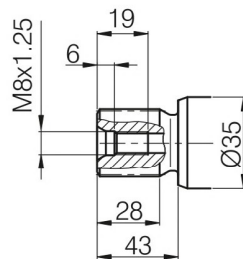

Sizes 23, 28, 32

**"B"** Parallel keyed shaft  
DIN 6885, AS8x7x40

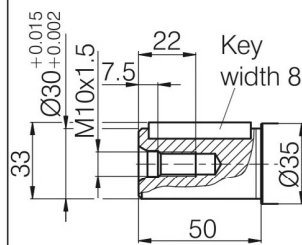

Sizes 23, 28

**"P"** Parallel keyed shaft  
DIN 6885, AS8x7x40

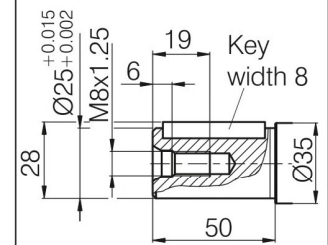

**Port details**

Designation	Port for	Standard	Maximum pressure (bar)
B/A	Service line, fastening thread B/A	SAE 1/2 in M8x1.25; 15 deep	400
S	Suction line, fastening thread	SAE 3/4 in M10x1.5; 17 deep	30
T1	Case drain line	M16x1.5; 12 deep	3
T2	Case drain line	M16x1.5; 12 deep	3
R	Air bleed	M10x1; 12 deep	3

## Unit Dimension Size 45

(Dimension in mm)

Port plate 05-SAE flange port A/B at side and SAE flange port S at rear

illustration: cw direction of rotation (on version "ccw direction of rotation" the port plate is rotated through 180°)

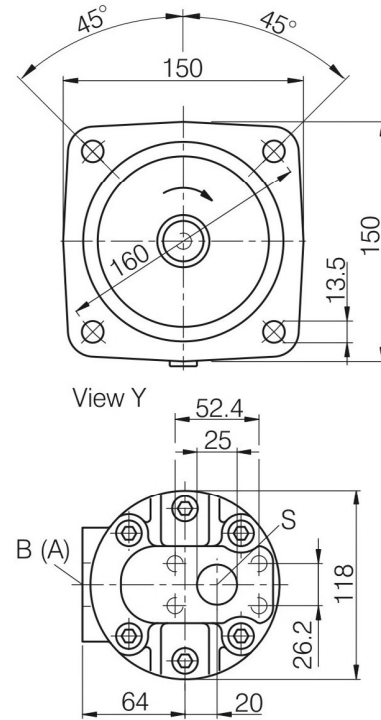
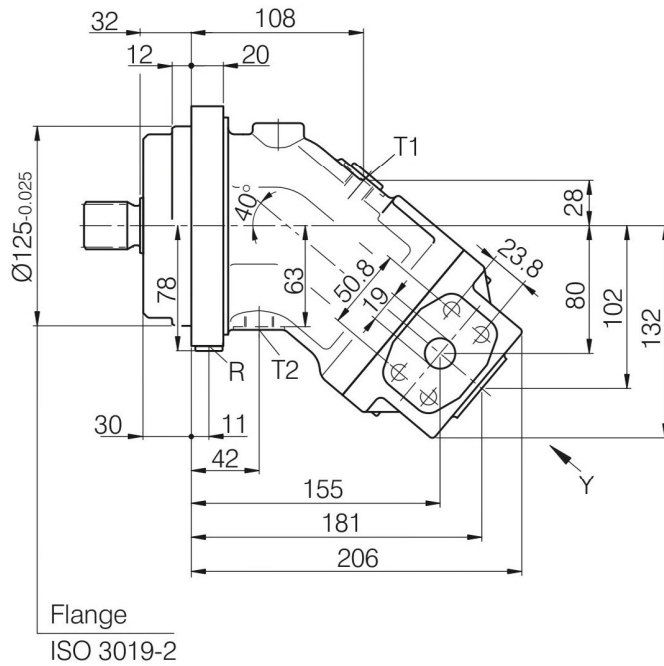

### Drive shaft

**"Z"** Splined shaft DIN5480  
W30x2x14x9g

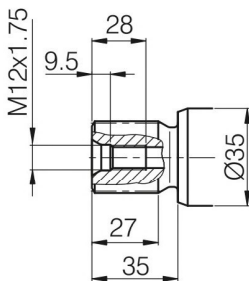

**"P"** Parallel keyed shaft  
DIN5480, AS8x7x50

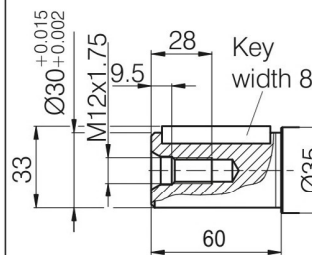

### Port details

Designation	Port for	Standard	Maximum pressure (bar)
B/A	Service line, fastening thread B/A	SAE 3/4 in M10x1.5; 17 deep	400
S	Suction line, fastening thread	SAE 1 in M10x1.5; 17 deep	30
T1	Case drain line	M18x1.5; 12 deep	3
T2	Case drain line	M18x1.5; 12 deep	3
R	Air bleed	M12x1.5; 12 deep	3

## Unit Dimension Size 56, 63

(Dimension in mm)

Port plate 05-SAE flange port A/B at side and SAE flange port S at rear

illustration: cw direction of rotation (on version "ccw direction of rotation" the port plate is rotated through 180°)

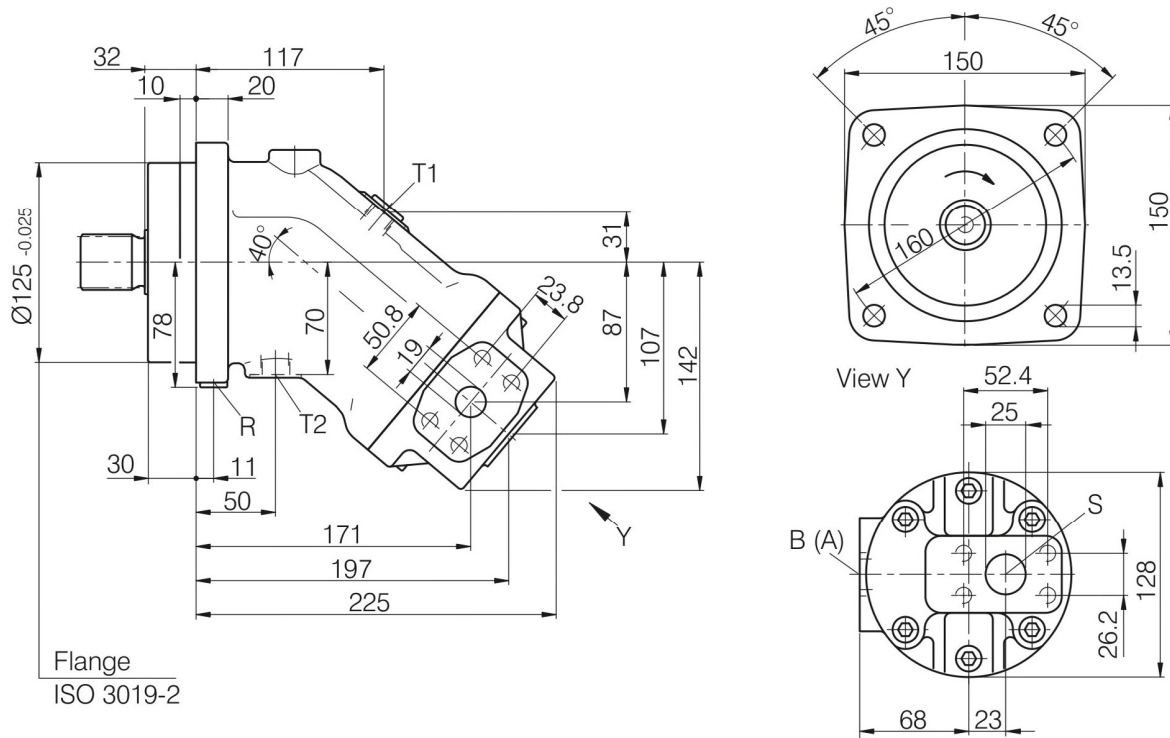

### Drive shaft

Size 56, 63

**"A"** Splined shaft DIN 5480  
W35x2x16x9g

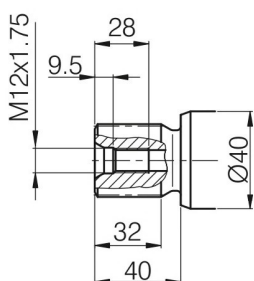

Size 56

**"Z"** Splined shaft DIN 5480  
W30x2x14x9g

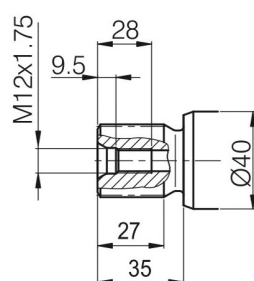

Size 56, 63

**"B"** Parallel keyed shaft  
DIN 6885 AS10x8x50

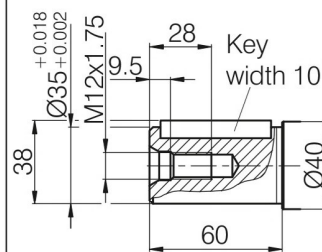

Size 56

**"P"** Parallel keyed shaft  
DIN 6885 AS8x7x50

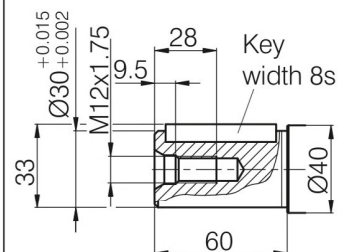

### Port details

Designation	Port for	Standard	Maximum pressure (bar)
B/A	Service line, fastening thread B/A	SAE 3/4 in M10x1.5; 17 deep	400
S	Suction line, fastening thread	SAE 1 in M10x1.5; 17 deep	30
T1	Case drain line	M18x1.5; 12 deep	3
T2	Case drain line	M18x1.5; 12 deep	3
R	Air bleed	M12x1.5; 12 deep	3



## Unit Dimension Size 80, 90

(Dimension in mm)

Port plate 05-SAE flange port A/B at side and SAE flange port S at rear

illustration: cw direction of rotation (on version "ccw direction of rotation" the port plate is rotated through 180°)

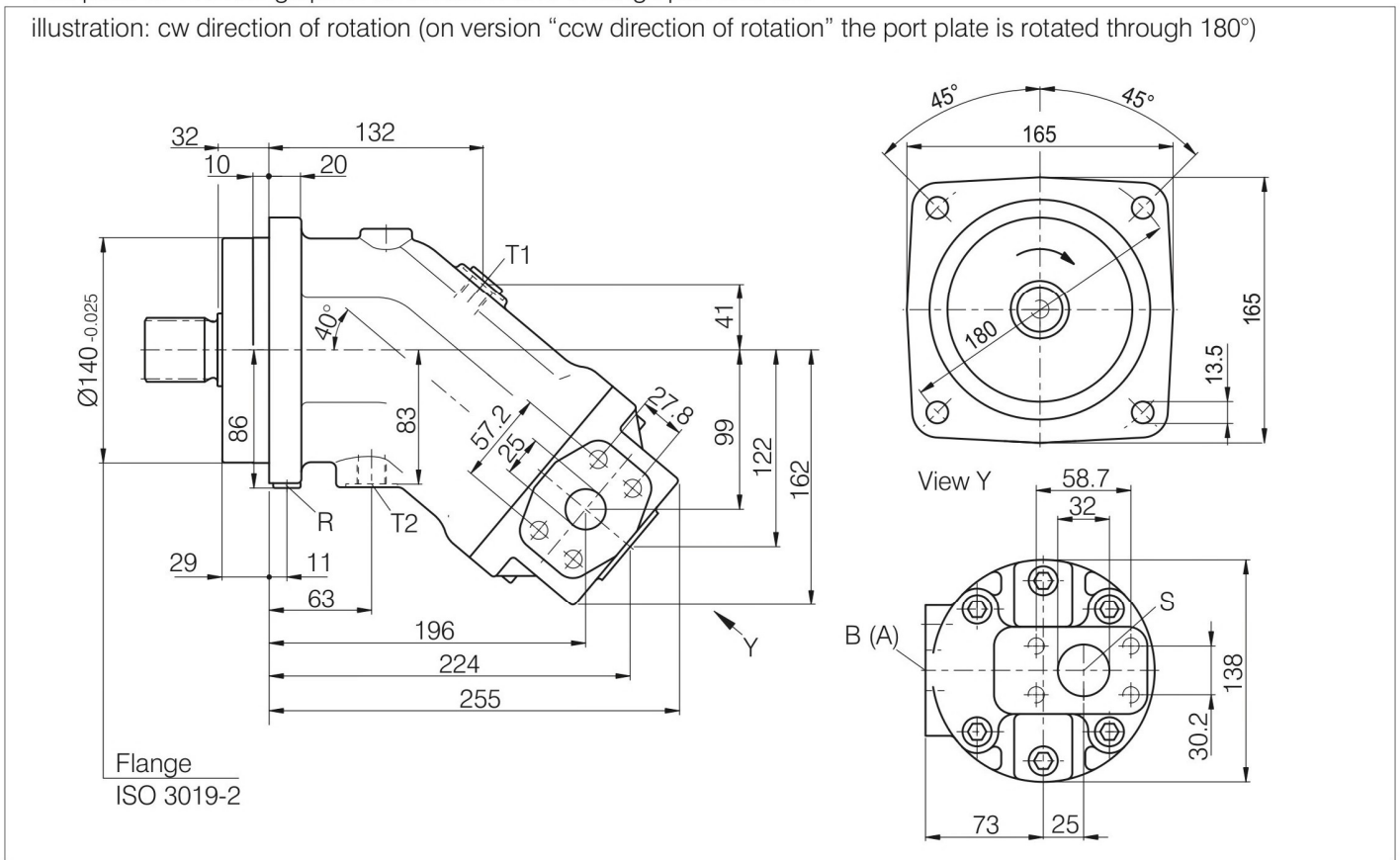

### Drive shaft

Size 80, 90

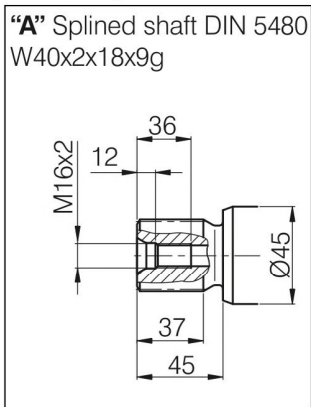

Size 80

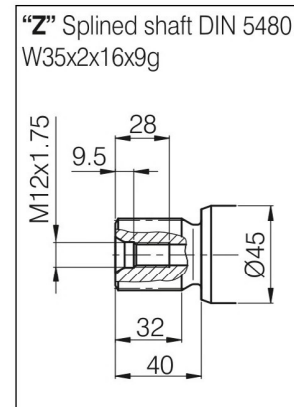

Size 80, 90

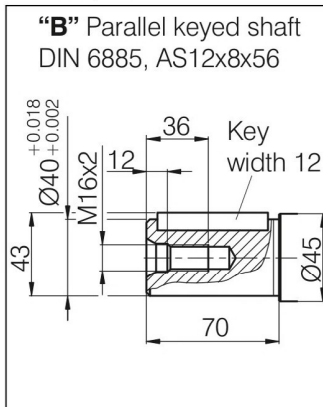

Size 80

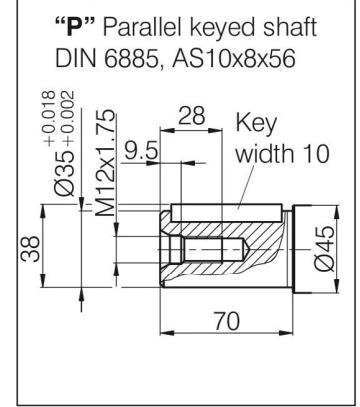

### Port details

Designation	Port for	Standard	Maximum pressure (bar)
B/A	Service line, fastening thread B/A	SAE 1 in M12x1.5; 17 deep	400
S	Suction line, fastening thread	SAE 1 1/4 in M10x1.5; 17 deep	30
T1	Case drain line	M18x1.5; 12 deep	3
T2	Case drain line	M18x1.5; 12 deep	3
R	Air bleed	M12x1.5; 12 deep	3

## Unit Dimension Size 107, 125

(Dimension in mm)

Port plate 05-SAE flange port A/B at side and SAE flange port S at rear

illustration: cw direction of rotation (on version "ccw direction of rotation" the port plate is rotated through 180°)

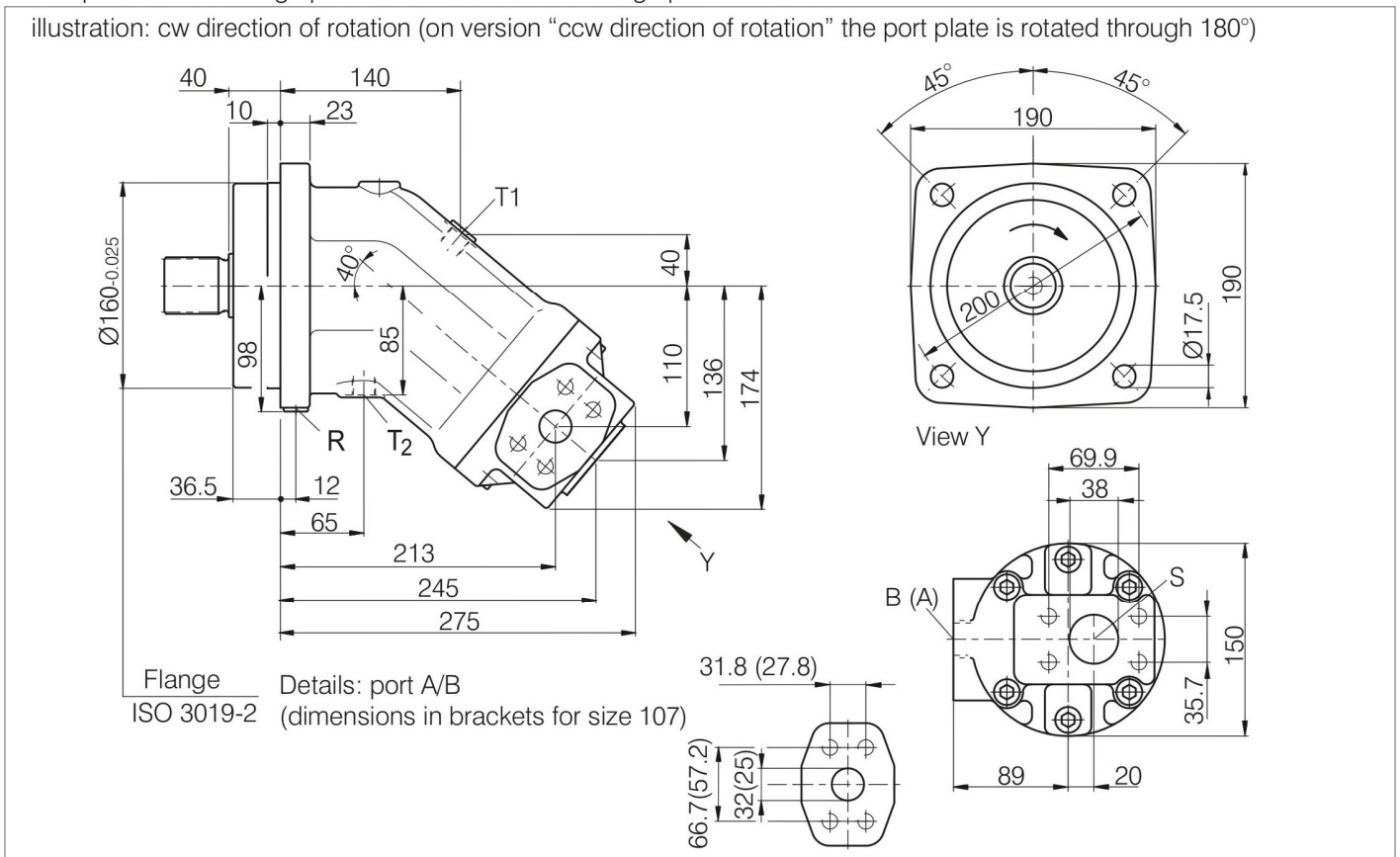

### Drive shaft

Size 107, 125

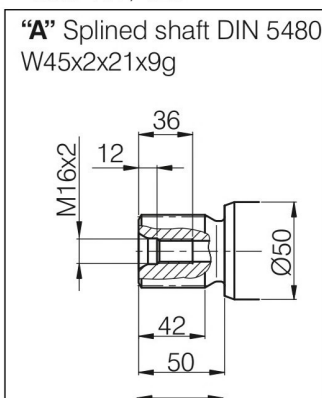

Size 107

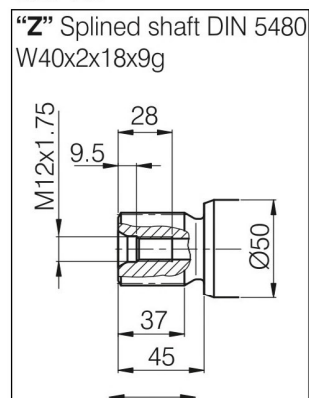

Size 107, 125

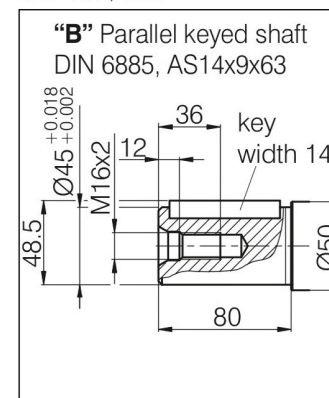

Size 107

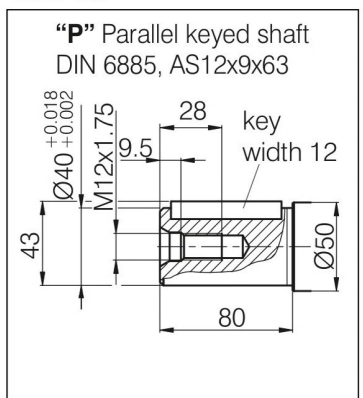

### Port details

Designation	Port for	Standard	Maximum pressure (bar)
B/A	Service line, fastening thread B/A	SAE 1 in (size107) M12x1.75;17 deep 1 1/4 in (size125) M14x2;19 deep	400
S	Suction line, fastening thread	SAE 1 1/2 in M12x1.75; 17 deep	30
T1	Case drain line	M18x1.5;12 deep	3
T2	Case drain line	M18x1.5;12 deep	3
R	Air bleed	M14x1.5; 12 deep	3

## Unit Dimension Size 160, 180

(Dimension in mm)

Port plate 05-SAE flange port A/B at side and SAE flange port S at rear

illustration: cw direction of rotation (on version "ccw direction of rotation" the port plate is rotated through 180°)

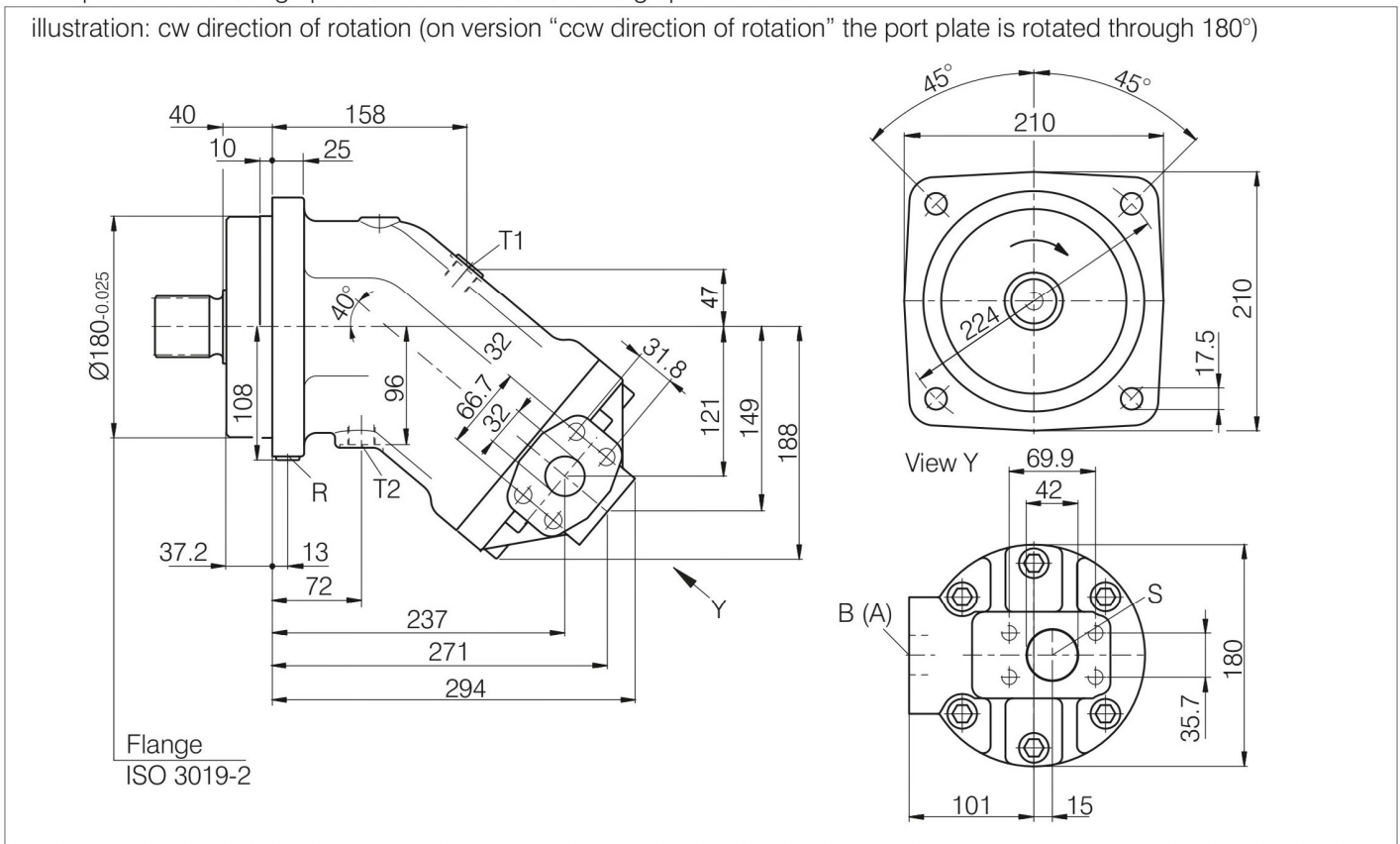

### Drive shaft

Size 160, 180

Size 160

Size 160, 180

Size 160

**"A"** Splined shaft DIN 5480  
W50x2x24x9g

**"Z"** Splined shaft DIN 5480  
W45x2x21x9g

**"B"** Parallel keyed shaft  
DIN 6885, AS14x9x70

**"P"** Parallel keyed shaft  
DIN 6885, AS14x9x70

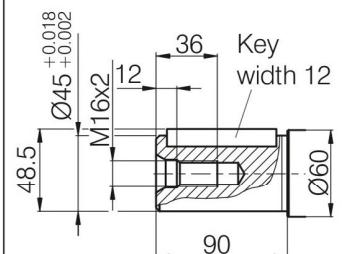
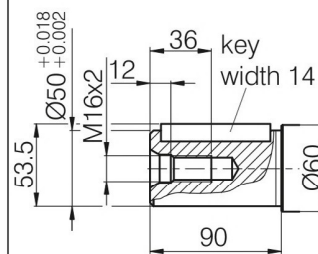
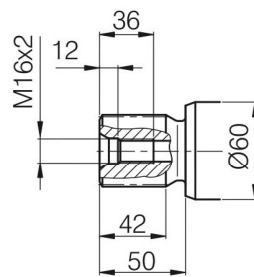
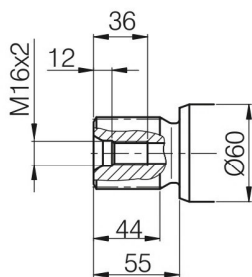

### Port details

Designation	Port for	Standard	Maximum pressure (bar)
B/A	Service line, fastening thread B/A	SAE 1 1/4 in M14x2; 19 deep	400
S	Suction line, fastening thread	SAE 1 1/2 in M12x1.75; 20 deep	30
T1	Case drain line	M22x1.5; 14 deep	3
T2	Case drain line	M22x1.5; 14 deep	3
R	Air bleed	M14x1.5; 12 deep	3

## Installation notes for A2FO Axial piston units

### Fixed pump A2FO, Series 6.1

Optimum filling orientation:

Air bleed port "R" standard in A2FO

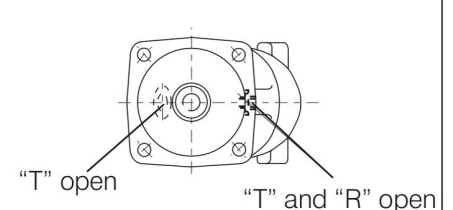
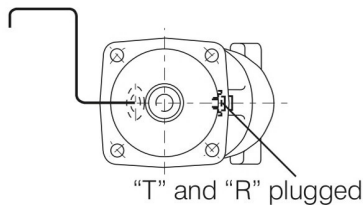
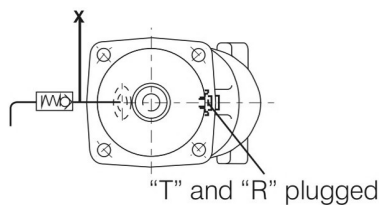
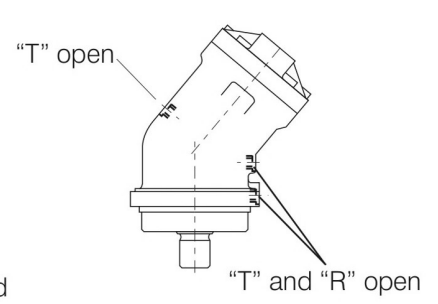
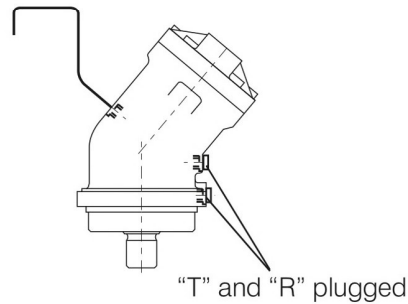
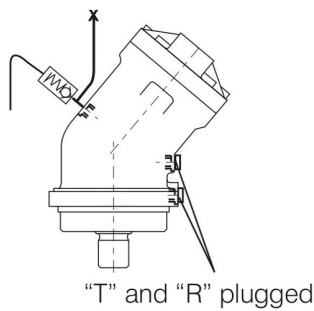
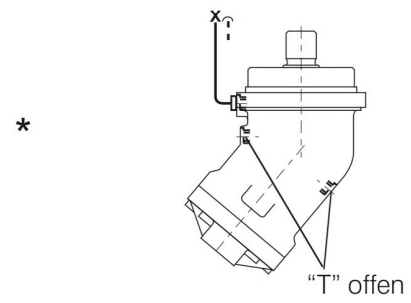
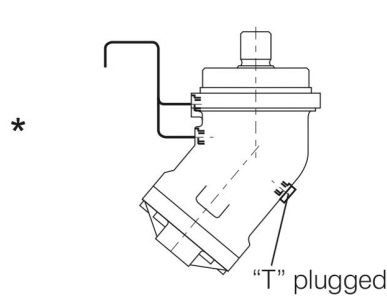
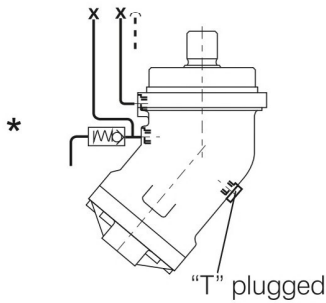
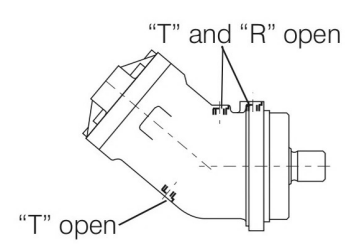
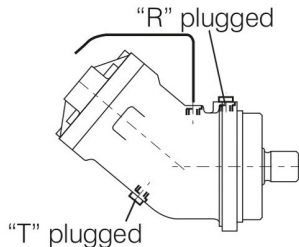
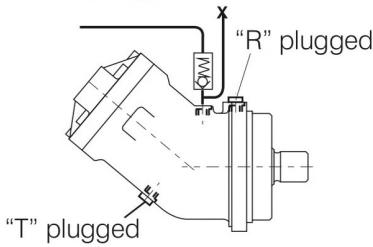
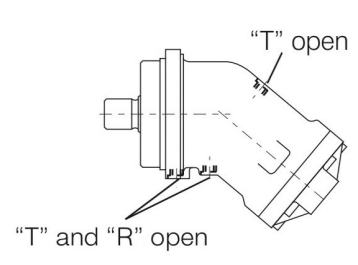
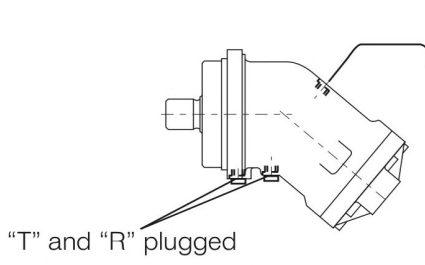
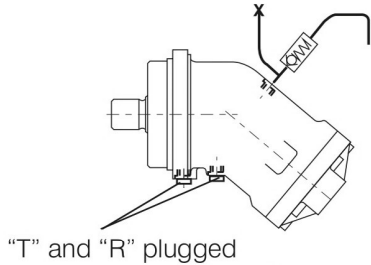
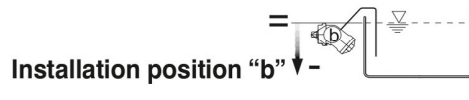
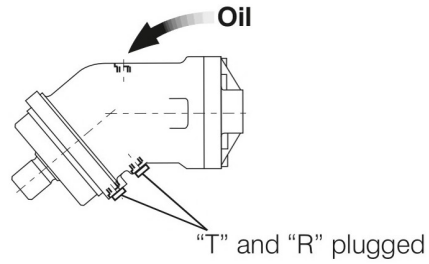

## Installation notes for A2FO Axial piston units

### General

During commissioning and operation, the axial piston unit must be filled with hydraulic fluid and air bled. This must also be observed following a relatively long standstill as the axial piston unit may drain back to the reservoir via the hydraulic lines. Particularly in the installation position "drive shaft upward" filling and air bleeding must be carried out completely as there is, for example, a danger of dry running.

The case drain fluid in the pump housing must be directed to the reservoir via the highest available drain port1 (TT2).

For combinations of multiple units, make sure that the respective case pressure in each unit is not exceeded. In the event of pressure differences at the drain ports of the units, the shared drain line must be changed so that the minimum permissible case pressure of all connected units is not exceeded in any situation. If this is not possible, separate drain lines must be laid if necessary. To achieve favorable noise values, decouple all connecting lines using elastic elements and avoid above-reservoir installation.

In all operating conditions, the suction and drain lines must flow into the reservoir below the minimum fluid level. The permissible suction height  $h_s$  results from the overall loss of pressure; it must not, however, be higher than  $h_{smax} = 800\text{mm}$ . The minimum suction pressure at port S must also not fall below 0.8bar absolute during operation and during cold start.

### Installation position

See the following examples 1 to 8

Further installation positions are possible upon request.

Recommended installation positions: 1 and 2

### Below-reservoir installation (standard)

Below-reservoir installation means that the axial piston unit is installed outside of the reservoir below the minimum fluid level.

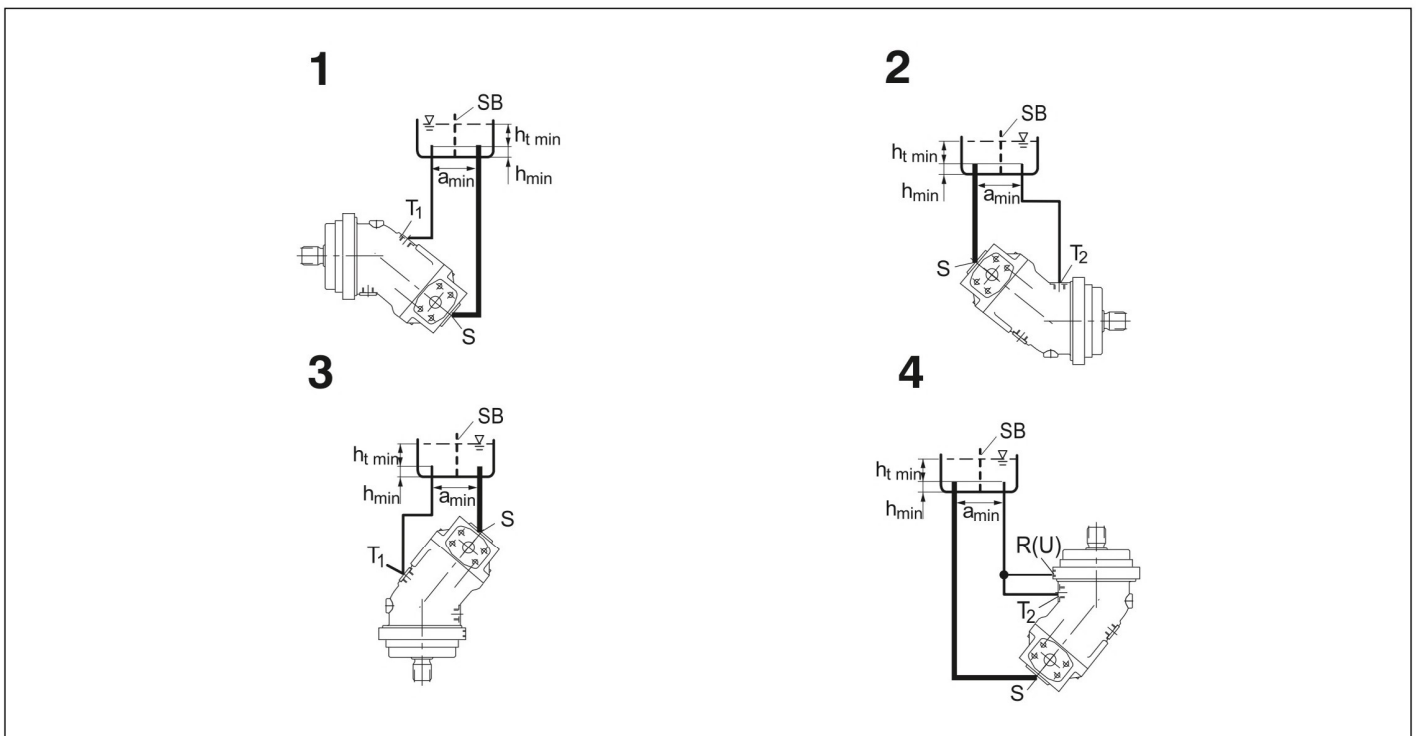

Installation position	Air bleed	Filling
1	-	T <sub>1</sub>
2	-	T <sub>2</sub>
3	-	T <sub>1</sub>
4	R (U) <sub>2</sub>	T

## Installation notes for A2FO Axial piston units

### Above-reservoir installation

Above-reservoir installation means that the axial piston unit is installed above the minimum fluid level of the reservoir.

Recommendation for installation position 8 (drive shaft upward): A check valve in the drain line (cracking pressure 0.5 bar) A check valve in the drain line (cracking pressure 0.5bar) can prevent draining of the pump housing.

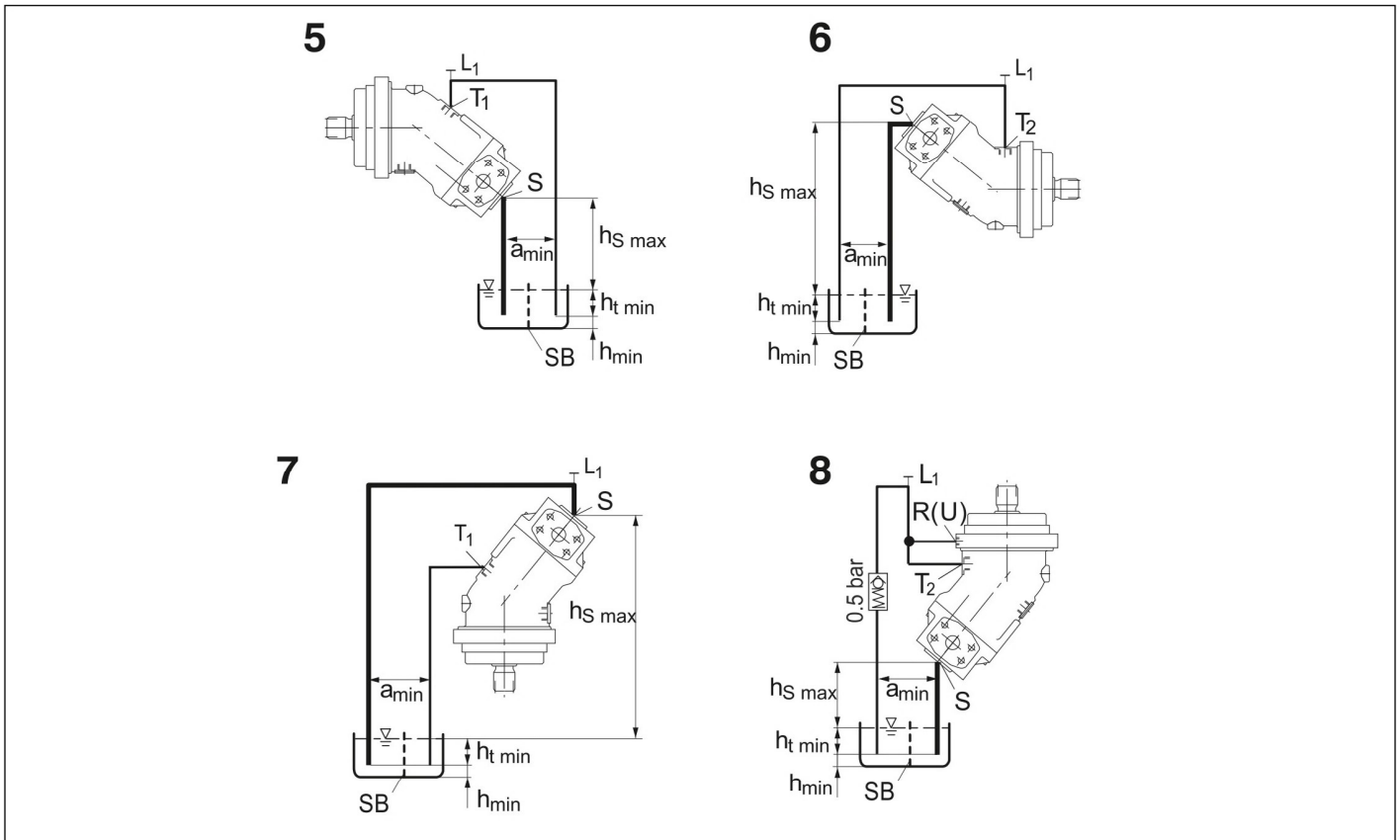

Installation position	Air bleed	Filling
5	L1	T <sub>1</sub> (L <sub>1</sub> )
6	L1	T <sub>2</sub> (L <sub>1</sub> )
7	L1	T <sub>1</sub> (L <sub>1</sub> )
8	R (U) <sub>2</sub>	T(L <sub>1</sub> )

- L1 Filling / air bleed
- R Air bleed port
- U Bearing flushing/ air bleed port
- S Suction port
- T<sub>1</sub>, T<sub>2</sub> Drain port
- h<sub>t min</sub> Minimum required immersion depth (200mm)
- h<sub>min</sub> Minimum required spacing to reservoir bottom (100mm)
- SB Baffle (Baffle plate)
- h<sub>s max</sub> Maximum permissible suction height (800mm)
- a<sub>min</sub> When designing the reservoir, ensure adequate space between the suction line and the drain line  
This prevents the heated, return flow from being

## General Instructions

- The pump A2FO is designed to be used in open circuits.
- The project planning, installation and commissioning of the axial piston unit requires the involvement of qualified personnel.
- Before using the axial piston unit, please read the corresponding instruction manual completely and thoroughly.
- During and shortly after operation, there is a risk of burns on the axial piston unit. Take appropriate safety measures (e. g. by wearing protective clothing).
- Depending on the operating conditions of the axial piston unit (operating pressure, fluid temperature), the characteristic may shift.
- Service line ports:
  - The ports and fastening threads are designed for the specified maximum pressure. The machine or system manufacturer must ensure that the connecting elements and lines correspond to the specified application conditions (pressure, flow, hydraulic fluid, temperature) with the necessary safety factors.
  - The service line ports and function ports can only be used to accommodate hydraulic lines.
- The data and notes contained herein must be adhered to.
- The product is not approved as a component for the safety concept of a general machine according to ISO 13849.
- A pressure-relief valve is to be fitted in the hydraulic system.
- The following tightening torques apply:
  - **Fittings:**  
Observe the manufacturer's instructions regarding tightening torques of the fittings used.
  - **Mounting bolts:**  
For mounting bolts with metric ISO thread according to DIN 13 or with thread according to ASME B1.1, we recommend checking the tightening torque in individual cases in accordance with VDI 2230.
  - **Female threads in the axial piston unit:**  
The maximum permissible tightening torques MG max are maximum values for the female threads and must not be exceeded. For values, see the following table.
  - **Threaded plugs:**  
For the metallic threaded plugs supplied with the axial piston unit, the required tightening torques of threaded plugs MV apply. For values, see the following table.

Ports standard	Size of standard	Maximum permissible tightening torque of the female threads $M_{G \max}$	Required tightening torque of the threaded plugs $MV$ 1)	WAF hexagon socket in the threaded plugs
DIN3852	M8 x 1	10 Nm	7 Nm	3 mm
	M10 x 1	30 Nm	15 Nm 2)	5 mm
	M12 x 1.5	50 Nm	25 Nm 2)	6 mm
	M14 x 1.5	80 Nm	35 Nm	6 mm
	M16 x 1.5	100 Nm	50 Nm	8 mm
	M18 x 1.5	140 Nm	60 Nm	8 mm
	M22 x 1.5	210 Nm	80 Nm	10 mm
	M33 x 2	540 Nm	225 Nm	17 mm
	M42 x 2	720 Nm	360 Nm	22 mm

- 1) The tightening torques apply for screws in the "dry" state as received on delivery and in the "lightly oiled" state for installation.  
2) In the "lightly oiled" state, the MV is reduced to 10 Nm for M10 x 1 and 17 Nm for M12 x 1.5.